

Agricultural Weighing

PRECISION FARMING MEASUREMENT

AG CELLS AND WEIGHT DISPLAYS

Cardinal's AG Cell design allows for easy installation in mobile farming applications by placing the AG Cell between the truck or trailer frame and its box. Heavy-duty construction compensates for shifting during moving of the cart or truck body.



Mobile Applications:

- Seed Carts
- Fertilizer Spreaders (truck and trailer)
- Feed Mixers (truck and trailer)

**Also works in static pallet and platform scale applications*



**Cardinal model 212
Weight Indicator**

0.8 inch high LCD display

**Powerful Potential for
Farming Applications.**

**Indicator Includes
Rear Shock
Absorber Mounts.**

212 and 212X FEATURES:

- IP65 Polycarbonate Enclosure.
- Backlit Transflective Display.
- 100 ID Locations Includes Load Count and Net Weight.
- 10-16 VDC Power.
- Optional: 115/230 VAC 50/60 HZ.
- Digital Fill Control with Load or Unload Operation and Accumulation of ID, Load Count, and Net Weight.
- Local/Remote Operation.
- Remote Inputs for START, ZERO/CLEAR, PRINT, 2XX-KEYFOB.
- Non-Commercial Agricultural Weighing Capabilities.
- Retrofit to Feed and Seed Cart Operations for Monitoring Weights.



**Cardinal model 212X
Weight Indicator**

2 inch high LCD display



The 212 and 212X are loaded with circular connectors for versatile options: relays, networking, serial, or remote displays.

- Four Load Cell Input
- No Junction Box Required
- Waterproof Circular Connectors

DIGITAL CALIBRATION METHODS

1. Enter the quantity of Cardinal AG load cells.
2. Enter the quantity and mv/v output of other load cells.
3. Apply test weights according to traditional calibration methods.

*** Test weights not required for 1 and 2.**



Cardinal model RD3 Remote Display

2 inch high LCD display

(1) serial port configurable with auto-detection

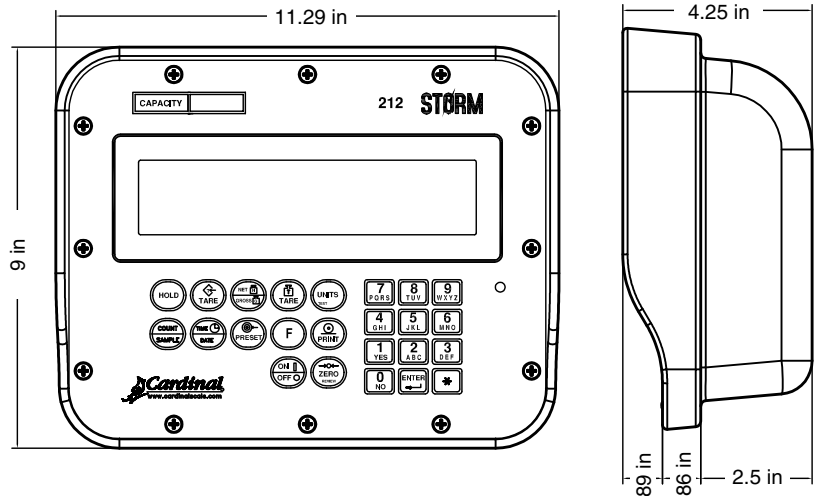

Versatile Design Ideal for Both Static and Mobile Applications.



For static applications, the AG Cell design allows for easy adaptation to the structure that is to be the weighing platform.

AG CELLS

- Polyurethane Sheathed Cables
- Potted Sealed Strain Gauges Protected by Steel Shroud
- Durable Alloy Steel Construction



Model AG750

Available in single cells (shown above) or with four cells in stands, Cardinal AG Cells are designed primarily for the agricultural industry. Environmental seals and coatings protect against rain, snow, dust, and mud. The four-point scale system (shown below) installs under mixers, tanks, or other bodies mounted on a trailer chassis or truck frame.

Model AG750-4 AG cell weigh beam load cell kit shown below.

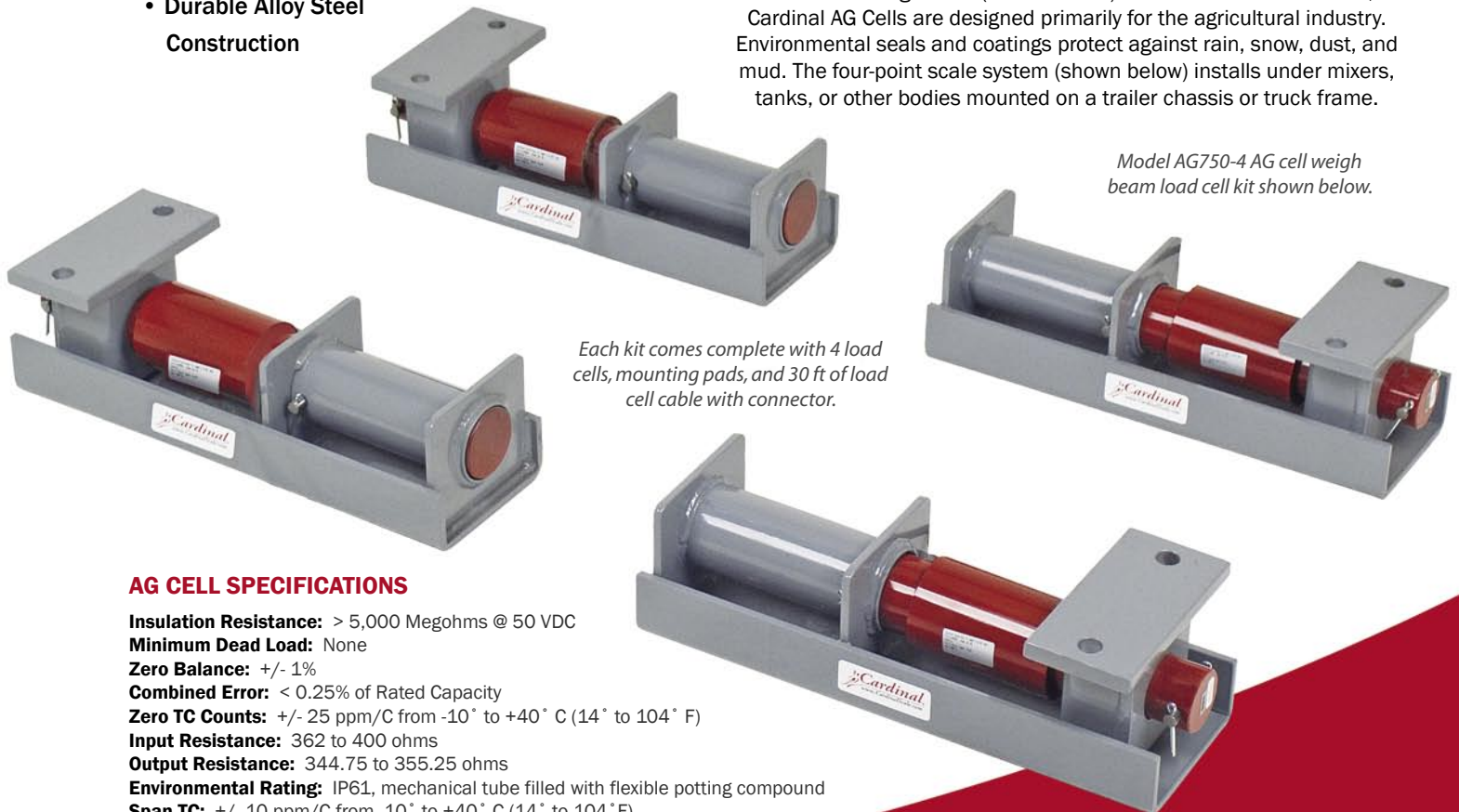

Each kit comes complete with 4 load cells, mounting pads, and 30 ft of load cell cable with connector.

AG CELL SPECIFICATIONS

- Insulation Resistance:** > 5,000 Megohms @ 50 VDC
- Minimum Dead Load:** None
- Zero Balance:** +/- 1%
- Combined Error:** < 0.25% of Rated Capacity
- Zero TC Counts:** +/- 25 ppm/C from -10° to +40° C (14° to 104° F)
- Input Resistance:** 362 to 400 ohms
- Output Resistance:** 344.75 to 355.25 ohms
- Environmental Rating:** IP61, mechanical tube filled with flexible potting compound
- Span TC:** +/- 10 ppm/C from -10° to +40° C (14° to 104° F)
- Overload Rating:** Do not exceed capacity rating of load cell

4-Load Cell Kits: AG750-4: 3,000 lb system capacity AG7.5K-4: 30,000 lb system capacity AG18K-4: 72,000 lb system capacity

AG Cell Series Weigh Beam Load Cells and Stand Assemblies

AG750 LOAD CELL ONLY

CAPACITY: 750 lb

OUTPUT MV/V: .800

DIAMETER: 1 in / 25 mm

STYLE: Cantilever

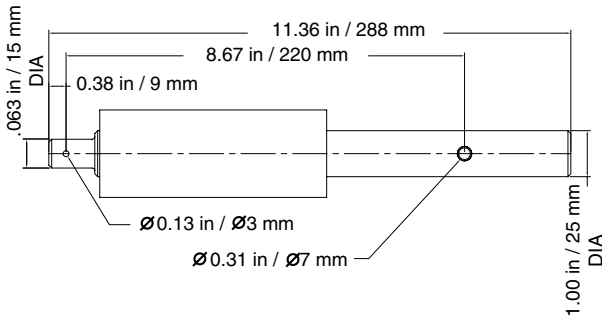

AG750-1 LOAD CELL WITH STAND

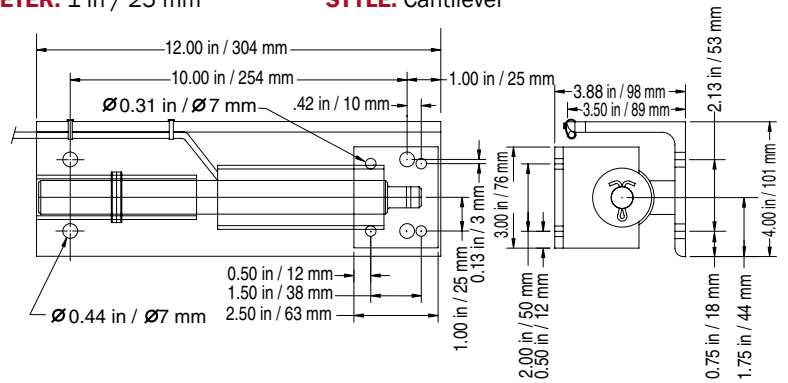

AG7.5K LOAD CELL ONLY

CAPACITY: 7,500 lb

OUTPUT MV/V: .800

DIAMETER: 2.12 in / 53 mm

STYLE: Cantilever

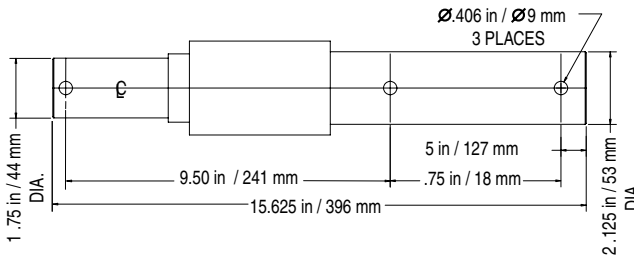

AG7.5K-1 LOAD CELL WITH STAND

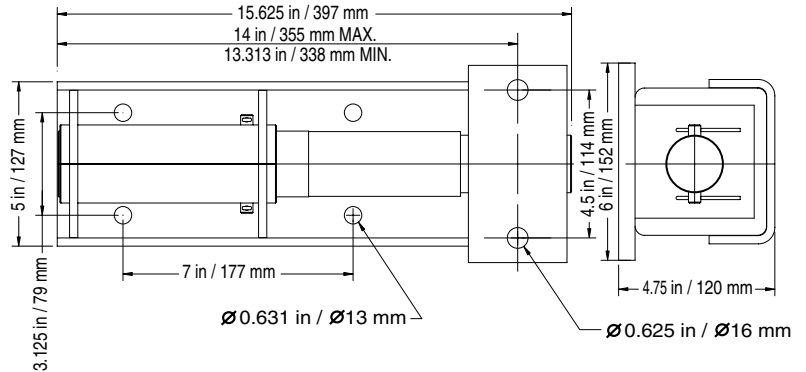

AG18K LOAD CELL ONLY

CAPACITY: 18,000 lb

OUTPUT MV/V: 1.345

DIAMETER: 2.5 in / 63 mm

STYLE: Cantilever

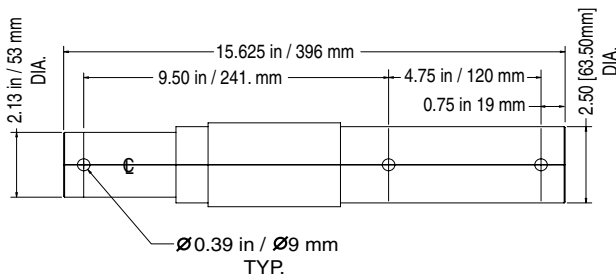

AG18K-1 LOAD CELL WITH STAND

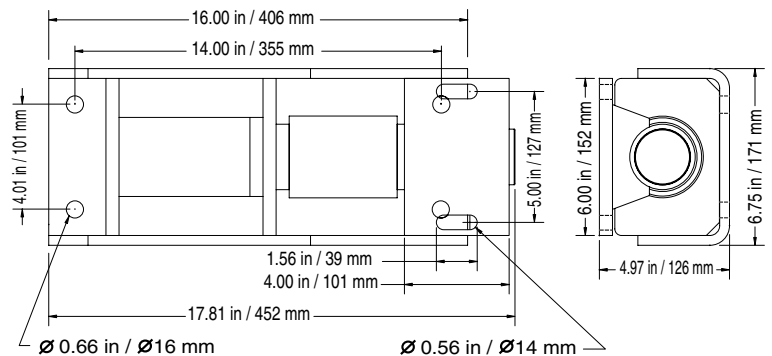

Cardinal Scale reserves the right to improve, enhance or modify features and specifications without prior notice. All registered trademarks are the property of their respective owners.

SOLD BY:

Cardinal
 Cardinal Scale Manufacturing Co.
 203 E. Daugerty, Webb City, MO 64870 USA
 Pb: 417-673-4631 or 800-441-4237 • Fax: 417-673-5001
www.CardinalScale.com

